



ToooAir

RG530 Quick Start Guide

Tooo Air Wide Area Platform

Tooo Air PTY LTD
Suite 1103, 1 Newland Street Bondi Junction, NSW 2022



RG530 Quick Start Guide

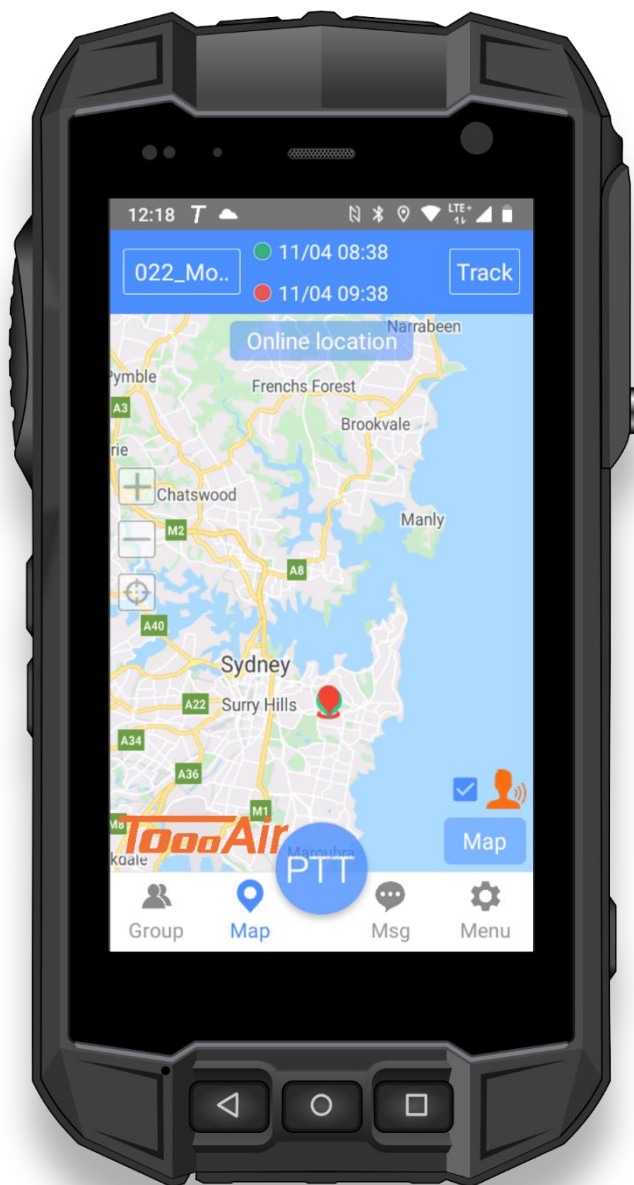

Thanks for choosing our product!

This Quick Start Guide is Only applicable to: RG530.

Before using the product, please read the Quick Start Guide to fully benefit from the RG530.

RG530 DIAGRAM

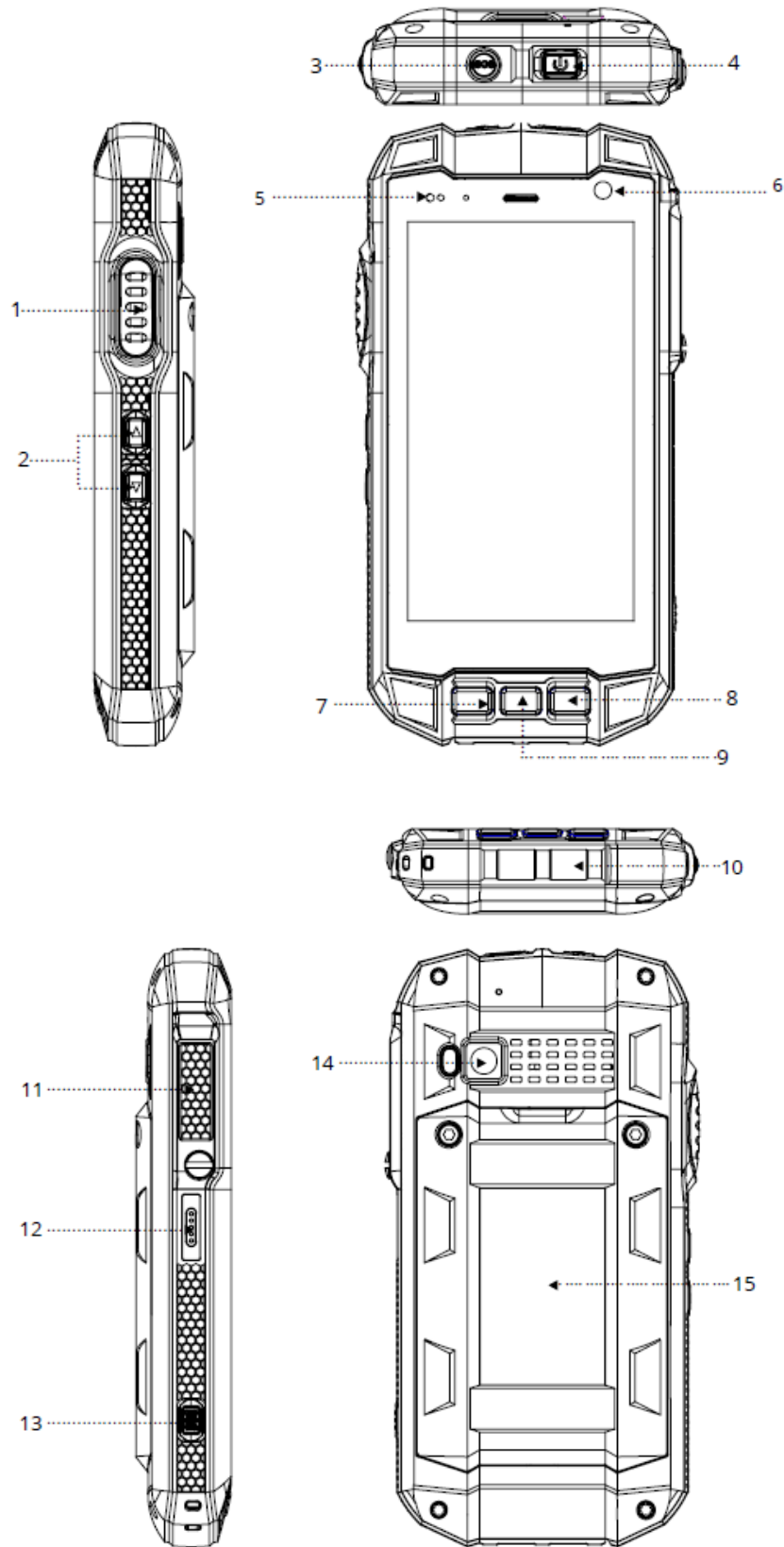

GETTING STARTED

- | | |
|---|-------------------------------------|
| 1_PTT key | 9_Home key, Returns to home screen. |
| 2_Volume buttons, Volume up/Volume down. | 10_USB Type-C Interface |
| 3_SOS key, press and hold for 3 seconds to trigger SOS | 11_13-pin Accessory Interface |
| 4_Power button, press and hold to power ON or OFF the device. Short press to turn ON or OFF the display | 12_Magnetic Charging Port |
| 5_LED Indicator | 13_Camera/Customizable key |
| 6_Front Camera. | 14_Rear Camera. |
| 7_Return key, Back to previous screen. | 15_Battery |
| 8_Recent Application key | |

Battery

The battery is not fully charged when the device is purchased, but it contains enough energy to power on the device. To obtain best battery performance and battery life, let the battery discharge completely before charging it completely for the first three charging cycles.

Charging

Pull out the USB rubber plug in the direction as shown in the figure and connect the cable to the phone to start charging. Only use RugGear wide licensed chargers and cables as unlicensed products may cause battery explosion or damage your device. You can only charge the device at ambient temperature range of +0°C to +45°C. The normal operating temperature of this mobile phone is -10°C to 50°C. It is recommended to use your mobile phone within this temperature range.

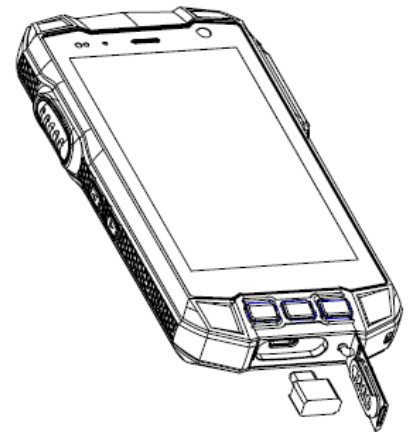

INSTALLATION

Battery Removal

Rotate the battery screw anticlockwise as shown until the battery is unscrewed. Lift the battery away from the device.

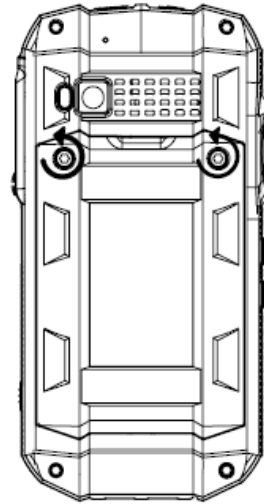

Card Installation/Removal

Install the Nano-SIM card and Micro SD card in the direction as shown. A memory card can be inserted to store additional multimedia data. This device can accept up to 128GB Micro SD memory card.

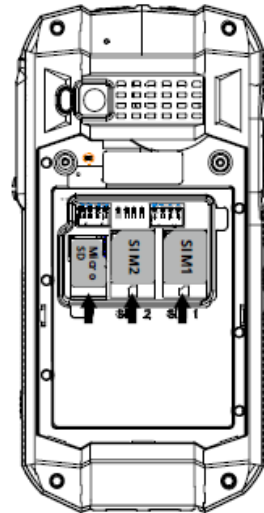

Battery Installation

Place battery into the back dock and close the battery, rotate the battery screw clockwise to firmly lock the battery to the device.

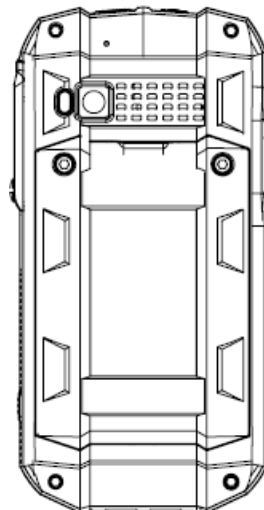

Note

After installation, please make sure that the USB port rubber plug of the whole phone are intact and closed to be waterproof and dust-proof.

Waist Clip Installation

The RG530 Waist Clip can be mounted on the rear battery as shown.

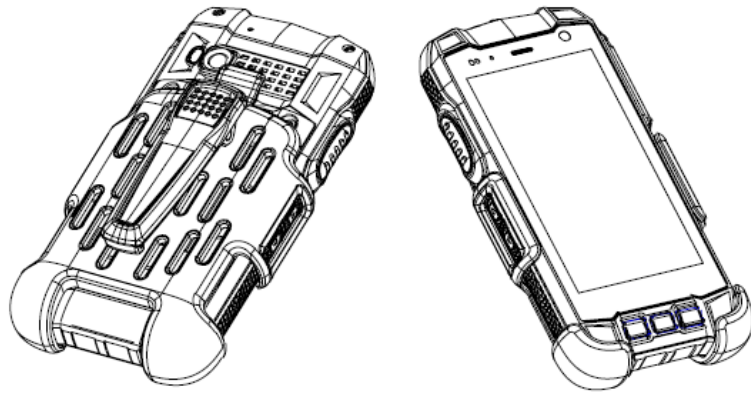
**IMPORTANT NOTICE****RECYCLING**

The crossed-out wheeled-bin symbol on your product, battery, literature, or packaging reminds you that all electrical and electronic products, batteries, and accumulators must be taken to separate collection at the end of their working life. Do not dispose of these products as unsorted municipal waste. Always return your used electronic products, batteries, and packaging materials to dedicated collection points. This way you help prevent uncontrolled waste disposal and promote the recycling of materials. More detailed information is available from the product retailer, local waste authorities or national producer responsibility organisations.

CAUTION

RG530 supports 5V/2A charging, using any higher charging current may damage your phone.

Risk of explosion if battery is replaced by an incorrect type. Dispose used batteries according to the instructions.

FURTHER SAFETY ADVICE

- Do not touch the screen of the device with sharp objects. Dust particles and nails may scratch the screen. Please maintain the screen clean. Remove dust on the screen with a soft cloth gently, and do not scratch the screen.
- Do not put the device in environments with excessive temperatures, as this could lead to heating of the battery, resulting in fire or explosion.
- Do not charge the device near any flammable or explosive substances.
- Charge the device under dry indoor conditions only.
- Do not charge the device in environments with much dust or humidity.
- Do not use the device in areas where regulations or legislatives prohibit the use.
- Do not expose the device or charger to strong magnetic fields, such as are emitted from induction ovens or microwaves.
- Do not attempt to open or repair the device. Improper repair or opening can lead to the destruction of the device, fire or explosion. Only authorized personnel are allowed to repair the device.
- Only use accessories approved by RugGear Ltd.
- Power off the device in hospitals or other places where the use of mobile phones is prohibited. This device may affect proper work of medical equipment, such as pacemakers. Always keep a distance of at least 15 cm between the device and these devices.
- Make sure the volume level is not set too high when plugging earphones and headphones to protect your hearing.
- Observe all corresponding laws that are in force in the respective countries regarding the

RG530 Quick Start Guide

use of devices while operating a vehicle.

- Please power off the device and disconnect the charging cable before cleaning the device.
- Do not use any chemical cleaning agents to clean the device or the charger. Use a damp and anti-static soft cloth for cleaning.
- The product should only be connected to a USB interface of version USB2.0.
- Do not discard old and abandoned lithium batteries into the trash, send them to designated waste disposal locations.
- The user alone is responsible for any and all damages and liabilities caused by malware down-loaded when using the network or other data-exchange functions of the device. TooAir Pty. Ltd. cannot be held responsible for any of these claims.

Push-To-Talk Application

For the TooAir PTT App please refer to our application guide on our website:

<https://www.tooair.com.au/Resources.aspx>

WARRANTY

This warranty against defects is given by Too Air Pty Ltd ABN 58 615 252 536

1. Consumer guarantees

Our goods and services come with guarantees that cannot be excluded under the Australian Consumer Law. For major failures with the service, you are entitled:

- 1.1 to cancel your service contract with us; and
- 1.2 to a refund for the unused portion, or to compensation for its reduced value.

You are also entitled to choose a refund or replacement for major failures with goods. If a failure with the goods or a service does not amount to a major failure, you are entitled to have the failure rectified in a reasonable time. If this is not done you are entitled to a refund for the goods and to cancel the contract for the service and obtain a refund of any unused portion. You are also entitled to be compensated for any other reasonably foreseeable loss or damage from a failure in the goods or service’.

2. Warranty against defects

2.1 This warranty is in addition to and does not limit, exclude or restrict your rights under the Competition and Consumer Act 2010 (Australia) or any other mandatory protection laws that may apply.

2.2 We warrant our goods to be free from defects in materials and workmanship for the warranty period of 12 months from the date of original sale. Subject to our obligations under clause 1.2, we will at our option, either repair or replace goods which we are satisfied are defective. We warrant any replacement parts for the remainder of the period of warranty for the goods into which they are incorporated.

2.3 To the extent permitted by law, our sole liability for breach of a condition, warranty or other obligation implied by law is limited

- (a) in the case of goods we supply, to any one of the following as we decide –
 - (i) the replacement of the goods or the supply of equivalent goods;
 - (ii) the repair of the goods;
 - (iii) the cost of repairing the goods or of acquiring equivalent goods;
- (b) in the case of services we supply, to any one of the following as we decide –
 - (i) the supplying of the services again;
 - (ii) the cost of having the services supplied again.

2.4 For repairs outside the warranty period, we warrant our repairs to be free from defects in materials and workmanship for three months from the date of the original repair. We agree to re-repair or replace (at our option) any materials or workmanship which we are satisfied are defective.

2.5 We warrant that we will perform services with reasonable care and skill and agree to investigate any complaint regarding our services made in good faith. If we are satisfied that the complaint is justified, and as our sole liability to you under this warranty (to the extent permitted at law), we agree to supply those services again at no extra charge to you.

2.6 To make a warranty claim you must before the end of the applicable warranty period, return the goods you allege are defective, provide written details of the defect, and give us an original or copy of the sales invoice or some other evidence showing details of the transaction.

2.7 Send your claim to:
 Too Air Pty Ltd. Suite 1103, 1 Newland Street, Bondi Junction NSW 2022.
 Tel: (02) 9157 0540
 Email: info@toooair.com.au

3. This warranty does not cover

This warranty will not apply in relation to:

- (a) goods modified or altered in any way;
- (b) repairs performed other than by our authorised representative;
- (c) defects or damage resulting from misuse, accident, impact or neglect;
- (d) goods improperly installed or used in a manner contrary to the relevant instruction manual; or
- (e) goods where the serial number has been removed or made illegal
- (f) goods connected to an incorrect power source

4. Warranty period

The warranty on the TooAir RG530 Smartphone and Power Adapter is 12 Months. No repair or replacement during the warranty period will renew or extend the warranty period past the period from the original date of purchase.